

**INSTITUTO DE CIENCIAS
DE LA CONSTRUCCIÓN
EDUARDO TORROJA**

C/ Serrano Galvache n. 4 28033 Madrid (Spain)
Tel.: (34) 91 302 04 40 Fax: (34) 91 302 07 00
direccion.ietcc@csic.es www.ietcc.csic.es

European Technical Assessment

ETA 15/0046 of 03/03/2015

English translation prepared by IETcc. Original version in Spanish language

General Part

Technical Assessment Body issuing the ETA designated according to Art. 29 of Regulation (EU) 305/2011:

Instituto de Ciencias de la Construcción Eduardo Torroja (IETcc)

Trade name of the construction product

Team Pro TP DA / TP DAL drop in anchor

Product family to which the construction product belongs

Deformation controlled anchor made of galvanized steel of sizes M6, M8, M10, M12, M16 and M20 for multiple use for non-structural applications in concrete

Manufacturer

TEAM PRO INTERNATIONAL FZCO
Office n° LBO07002. Jebel Ali. Dubai.
United Arab Emirates
Webpage: www.team-pro.info

Manufacturing plant

Team Pro plant 2

This European Technical Assessment contains

9 pages including 4 annexes which form an integral part of this assessment. **Annex E contains confidential information and is not included in the European Technical Assessment when that assessment is publicly available.**

This European Technical Assessment is issued in accordance with regulation (EU) No 305/2011, on the basis of

Guideline for European Technical Approval ETAG 001 "Metal anchors for used in concrete", ed. April 2013, Parts 1 and 6 used as European Assessment Document (EAD)

Translations of this European Technical Assessment in other languages shall fully correspond to the original issued document and should be identified as such.

Communication of this European Technical Assessment, including transmission by electronic means, shall be in full (excepted the confidential annex referred to above). However, partial reproduction may be made, with the written consent of the issuing Technical Assessment Body. Any partial reproduction has to be identified as such.

This European Technical Assessment may be withdrawn by the issuing Technical Assessment Body, in particular pursuant to information by the Commission according to Article 25 Paragraph 3 of Regulation (EU) No 305/2011.

SPECIFIC PART

1. Technical description of the product

The Team Pro TP DA / TP DAL in the range of M6 to M20 is an anchor made of galvanised steel, which is placed into a drilled hole and anchored by deformation-controlled expansion.

The Team Pro TP DA / TP DAL anchor in the range of M6 to M20 corresponds to the picture and provisions given in annexes A and B. The anchor consists on an anchor body and an internal plug. The characteristic material values, dimensions and tolerances of the anchor not indicated in annexes A and B shall correspond to the respective values laid down in the technical documentation ⁽¹⁾ of this European Technical Assessment.

For the installation process see figure given in annex C; a specific setting tool must be used. For the installed anchor see figure given in annex D. The fixture shall be anchored with a fastening screw or threaded rod of classes 4.6, 5.6, 5.8, 6.8 or 8.8 according to ISO 898-1.

Each sleeve is marked with the identifying mark of the producer, the trade name and the bolt metric size.

The performance of the anchor, including installation data, characteristic anchor values and displacements for the design of anchorages, is given in chapter 3.

The anchor shall only be packaged and supplied as a complete unit.

2. Specification of the intended use in accordance with the applicable EAD.

2.1 Intended use

The anchor is intended to be used for anchorages for which requirements for mechanical resistance and stability, safety in case of fire and safety and accessibility in use in the sense of the basic requirements 1, 2 and 4 of Construction Product Regulation no 305/2011 shall be fulfilled and failure of anchorages made with these products would compromise the stability of the works, cause risk to human life and/or lead to considerable economic consequences. The anchor is to be used only for multiple use for non-structural applications. The definition of multiple use according to the Member States is given in the informative annex 1 of ETAG 001, part 6.

The anchor may be used for anchorages with requirements related to resistance to fire.

The anchor is to be used only for anchorages subject to static or quasi-static loading in reinforced or unreinforced normal weight concrete of strength class C12/15 to C50/60, according to ENV 206: 1990-03. It may be anchored in cracked or non-cracked concrete. The anchor may only be used if in the design and installation specifications for the fixture the excessive slip or failure of one anchor will not result in a significant violation of the requirements on the fixture in the serviceability and ultimate state.

The Team Pro TP DA / TP DAL anchor may only be used in concrete subject to dry internal conditions.

The provisions made in this European Technical Approval are based on an assumed working life of the anchor of 50 years. The assumed working life is the foreseen period of time throughout which the

⁽¹⁾ The quality plan has been deposited at Instituto Eduardo Torroja de ciencias de la construcción and is only made available to the notified bodies involved in the AVCP procedure.

construction product, as installed into the construction work, will keep its performances allowing the construction work, behaving under predictable actions and with normal maintenance, to meet the basic requirements for construction works.

3. Performance of the product and references to the methods used for its assessment

The identification tests and the assessment for the intended use of this anchor according to the Basic Requirements (BR) were carried out in compliance with the ETAG 001. The characteristics of the components shall correspond to the respective values laid down in the technical documentation of this ETA, checked by IETcc.

3.1 Mechanical resistance and stability (BR 1)

Mechanical resistance and stability has been assessed according to ETAG 001 “Metal anchors to be used in concrete”, parts 1 and 6.

Installation parameters			Performance					
			M6	M8	M10	M12	M16	M20
d_o	Nominal diameter of drill bit:	[mm]	8	10	12	15	20	25
D	Thread diameter:	[mm]	M6	M8	M10	M12	M16	M20
d_f	Fixture clearance hole diameter:	[mm]	7	9	12	14	18	22
T_{inst}	Maximum installation torque:	[Nm]	4	11	17	38	60	100
$l_{s,min}$	Minimum screwing depth:	[mm]	6	8	10	12	16	20
$l_{s,max}$	Maximum screwing depth:	[mm]	10	13	17	21	27	34
h_{min}	Minimum thickness of concrete member:	[mm]	100	100	100	100	130	160
h_1	Depth of drilled hole:	[mm]	27	33	43	54	70	86
h_{nom}	Overall anchor embedm. depth in the concrete:	[mm]	25	30	40	50	65	80
h_{ef}	Effective anchorage depth:	[mm]	25	30	40	50	65	80
s_{min}	Minimum allowable spacing:	[mm]	60	90	80	100	130	160
c_{min}	Minimum allowable distance:	[mm]	105	105	140	175	230	280

Characteristic values of resistance to loads of design method B			Performance					
			M6	M8	M10	M12	M16	M20
All load directions								
F_{Rk}^0	Tension characteristic resistance in C12/15 concrete:	[kN]	1,5	3,0	4,0	6,0	9,0	16,0
F_{Rk}^0	Tension characteristic resistance in C20/25 to C50/60 concrete:	[kN]	2,0	3,0	5,0	7,5	12,0	20,0
γ_M	Partial safety factor: ¹⁾	[-]	1,8	1,8	2,1	2,1	2,1	2,1
$s_{cr,N}$	Characteristic spacing	[mm]	75	90	120	150	195	240
$c_{cr,N}$	Characteristic edge distance	[mm]	38	45	60	75	98	120
$s_{cr,sp}$	Characteristic spacing (splitting)	[mm]	50	60	80	100	130	160
$c_{cr,sp}$	Characteristic edge distance (splitting)	[mm]	75	90	120	150	195	240
Shear loads: steel failure with lever arm								
$M_{Rk,s}^0$	Characteristic bending moment, steel class 4.6	[Nm]	6,1	15,0	29,9	52,4	133,3	259,8
γ_{Ms}	Partial safety factor: ¹⁾	[-]	1,67	1,67	1,67	1,67	1,67	1,67
$M_{Rk,s}^0$	Characteristic bending moment, steel class 4.8	[Nm]	6,1	15,0	29,9	52,4	133,3	259,8
γ_{Ms}	Partial safety factor: ¹⁾	[-]	1,25	1,25	1,25	1,25	1,25	1,25
$M_{Rk,s}^0$	Characteristic bending moment, steel class 5.6	[Nm]	7,6	18,8	37,4	65,5	166,6	324,8
γ_{Ms}	Partial safety factor: ¹⁾	[-]	1,67	1,67	1,67	1,67	1,67	1,67
$M_{Rk,s}^0$	Characteristic bending moment, steel class 5.8	[Nm]	7,6	18,8	37,4	65,5	166,6	324,8
γ_{Ms}	Partial safety factor: ¹⁾	[-]	1,25	1,25	1,25	1,25	1,25	1,25
$M_{Rk,s}^0$	Characteristic bending moment, steel class 6.8	[Nm]	9,2	22,5	44,9	78,7	199,9	389,7
γ_{Ms}	Partial safety factor: ¹⁾	[-]	1,25	1,25	1,25	1,25	1,25	1,25
$M_{Rk,s}^0$	Characteristic bending moment, steel class 8.8	[Nm]	12,2	30,0	59,9	104,9	266,6	519,7
γ_{Ms}	Partial safety factor: ¹⁾	[-]	1,25	1,25	1,25	1,25	1,25	1,25

¹⁾ in absence of other national regulations

3.2 Safety in case of fire (BR 2)

Reaction to fire has been assessed according to Commission Decision 96/603/EC, amended by 2000/605/EC. Resistance to fire has been assessed in C20/25 to C50/60 concrete according to Technical Report 020: "Evaluation of anchorages in concrete concerning resistance to fire"

Characteristic resistance under fire exposure in concrete C20/25 to C50/60 in any load direction for use in concrete		Performance					
		M6	M8	M10	M12	M16	M20
R30	Characteristic resistance $F_{Rk,fi30}^0$ ¹⁾ [kN]	--	0.4	0.9	1.7	3.1	4.9
R60	Characteristic resistance $F_{Rk,fi60}^0$ ¹⁾ [kN]	--	0.3	0.8	1.3	2.4	3.7
R90	Characteristic resistance $F_{Rk,fi90}^0$ ¹⁾ [kN]	--	0.3	0.6	1.1	2.0	3.2
R120	Characteristic resistance $F_{Rk,fi120}^0$ ¹⁾ [kN]	--	0.2	0.5	0.8	1.6	2.5
R30 to R120	Spacing $s_{cr,fi}$ [mm]	--	120	160	200	260	320
	Edge distance $c_{cr,fi}$ [mm]	--	60	80	100	130	160
Reaction to fire		Class A1					

¹⁾ in absence of other national regulations the partial safety factor for resistance under fire exposure $\gamma_{M,fi} = 1.0$ is recommended. Design under fire exposure is performed according to the design method given in TR 020. Under fire exposure usually cracked concrete is assumed. The design equations are given in TR 020, Section 2.2.1. TR 020 covers design for fire exposure from one side. If fire attack is from more than one side, the design method may be taken if edge distance of the anchor is $c \geq 300$

3.3 Hygiene, health and the environment (BR 3)

This requirement is not relevant for the anchor.

3.4 Safety in use (BR 4)

Requirements with respect to the safety in use are not included in this Basic Requirement but are treated under the Essential Requirement Mechanical Resistance and Stability (see section 3.1)

3.5 Protection against noise (BR 5)

This requirement is not relevant for the anchor.

3.6 Energy economy and heat retention (BR 6)

This requirement is not relevant for the anchor.

3.7 Sustainable use of natural resources (BR 7)

No performance determined

4. System of attestation of conformity

According to the decision 96/582/EC of the European Commission ⁽²⁾ the system of assessment and verification of constancy of performance (see Annex V to Regulation (EU) No 305/2011) given in the following table applies:

Product	Intended use	Level or class	System
Team Pro drop in anchor TP DA / TP DAL	To be used for fixing and/or supporting structural elements	All / any	1

⁽²⁾ Published in the Official Journal of the European Union (OJEU) L254 of 24.06.1996 See www.new.eur-lex.europa.eu/oj/direct-access.html

The system 1, referred above is described in Construction Products Regulation (EU) No. 305/211 Annex V §. 1.3 as follows:

- a) The manufacturer shall carry out:
 - (i.) Factory production control.
 - (ii.) Further testing of samples taken at the factory by the manufacturer in accordance with the prescribed test plan;
- b) The notified production control certification body shall issue the certificate of conformity of the factory production control on the basis of:
 - (i.) Determination of the product-type on the basis of type testing (including sampling) calculation, tabulated values of descriptive documentation of the product:
 - (ii.) Initial inspection of factory and of factory production control.
 - (iii.) Continuous surveillance, assessment and evaluation of factory production

5. Technical details necessary for the implementation of the AVCP system, as provided for in the applicable EAD

The ETA is issued for this anchor on the basis of agreed data/information which identifies the product that has been assessed and judged. Detailed description and conditions of the manufacturing process of the anchor, and all the relevant design and installation criteria of this anchor are specified in the manufacturer's technical documentation deposited to the IETcc. The main aspects of this information are specified in the following sections. It is the manufacturer's responsibility to make sure that all those who use the anchor are appropriately informed of specific conditions according to sections 1, 2, 4 and 5 including the annexes of this ETA.

5.1 Tasks of the manufacturer

5.1.1 Factory production control

The manufacturer has a factory production control system and shall exercise permanent internal control of production. All the elements, requirements and provisions adopted by the manufacturer shall be documented in a systematic manner in the form of written policies and procedures, including records of results performed. This production control system shall insure that the product is in conformity with this ETA.

The manufacturer shall only use raw materials supplied with the relevant inspection documents as laid down in the quality plan ⁽³⁾. The incoming raw materials shall be subjected to controls by the manufacturer before acceptance. Check of materials shall include control of the inspection documents presented by suppliers by verifying dimension and material properties, e.g. chemical composition, mechanical properties etc. The manufactured components are checked visually, for dimensions and properties, where appropriate.

The quality plan which is part of the Technical Documentation of this ETA, includes details of the extent, nature and frequency of testing and controls to be performed within the factory production control and has been agreed between the assessment holder and IETcc. The results of factory production control shall be recorded and evaluated in accordance with the provisions of the quality plan. The records include at least the following information:

⁽³⁾ the quality plan has been deposited at IETcc and is only made available to the notified bodies involved in the ACVP procedure.

- Designation of the product, the basic materials and components;
- Type of control or testing and minimum frequencies of them;
- Date of manufacture of the product and date testing of the product or basic material and components;
- Results of controls and testing and, if appropriate, comparison with requirements;
- Signature of person responsible for factory production control.

The records shall be presented to the notified body involved in the continuous surveillance. On request, they shall be presented to the IETcc.

5.2 Tasks of notified bodies

5.2.1 Determination of the product-type on the basis of type testing

For type-testing the results of the tests performed as part of the assessment for the European Technical Assessment shall be used unless there are changes in the production line or plant. In such cases the necessary type testing has to be agreed between ETA holder and the notified body.

5.2.2 Initial inspection of factory and of factory production control

The notified body shall ascertain that, in accordance with the quality plan, the factory and the factory production control are suitable to ensure continuous and orderly manufacturing of the product according to the specifications mentioned in annex A of this the European Technical Assessment.

5.2.3 Continuous surveillance

The notified body shall visit the factory at least once a year for regular inspection.

This continuous surveillance and assessment of factory production control have to be performed according to the quality plan. The system of factory production control and the specified manufacturing process has to be verified that they are maintained as the quality plan defined. The results of product certification and continuous surveillance shall be made available on demand by the product certification body or factory production control body, respectively, to IETcc. In cases where the provisions of the European Technical Assessment and the quality plan are no longer fulfilled the conformity certificate shall be withdrawn.



Instituto de Ciencias de la Construcción Eduardo Torroja
CONSEJO SUPERIOR DE INVESTIGACIONES CIENTÍFICAS

c/ Serrano Galvache nº 4. 28033 Madrid.
Tel: (34) 91 302 04 40 Fax. (34) 91 302 07 00
www.ietcc.csic.es

On behalf of the Instituto de Ciencias de la Construcción Eduardo Torroja
Madrid, 03/03/2015



Marta Mª Castellote Armero
Director

INDEX OF ANNEXES:

Annex A: Assembled anchor

Annex B. Materials

Annex C. Installation process

Annex D. Schema of the anchor in use

Annex A: Assembled anchor

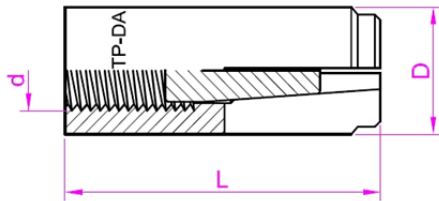

TP DA anchor

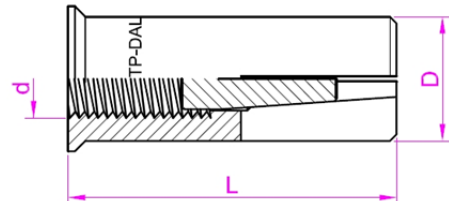

TP DAL anchor

Identification on sleeve: Team Pro logo + “TP DA (TP DAL)” + Metric; e.g.  TP DA M6

Anchor dimensions	M6	M8	M10	M12	M16	M20
ØD: External diameter [mm]	8	10	12	15	20	25
Ød: internal diameter [mm]	M6	M8	M10	M12	M16	M20
L: total length [mm]	25	30	40	50	65	80

Setting tool

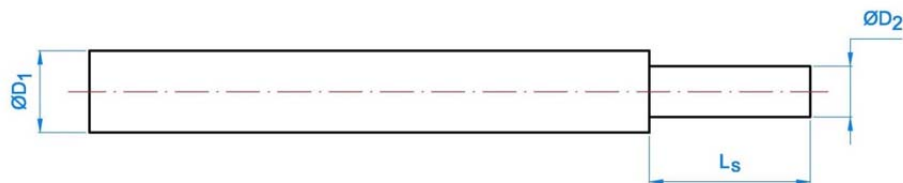

Setting tool dimensions	M6	M8	M10	M12	M16	M20
Ø D ₁ [mm]	7,5	9,5	11,5	14,5	18,0	22,0
Ø D ₂ [mm]	5,0	6,5	8,0	10,2	13,5	16,5
L _s [mm]	15	18	24	30	36	50

Setting tool could be assembled with a plastic handle for hand protection purposes

Annex B. Materials

Item	Designation	Material
1	Sleeve	Carbon steel wire rod, zinc plated ≥ 5 µm ISO 4042 A2
2	Expansion plug	Carbon steel wire rod, zinc plated ≥ 5 µm ISO 4042 A2

Annex C. Installation process

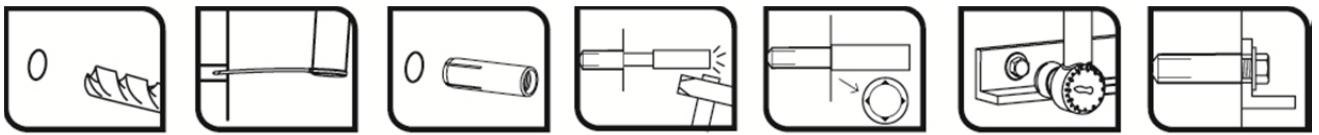

Annex D. Schema of the anchor in use

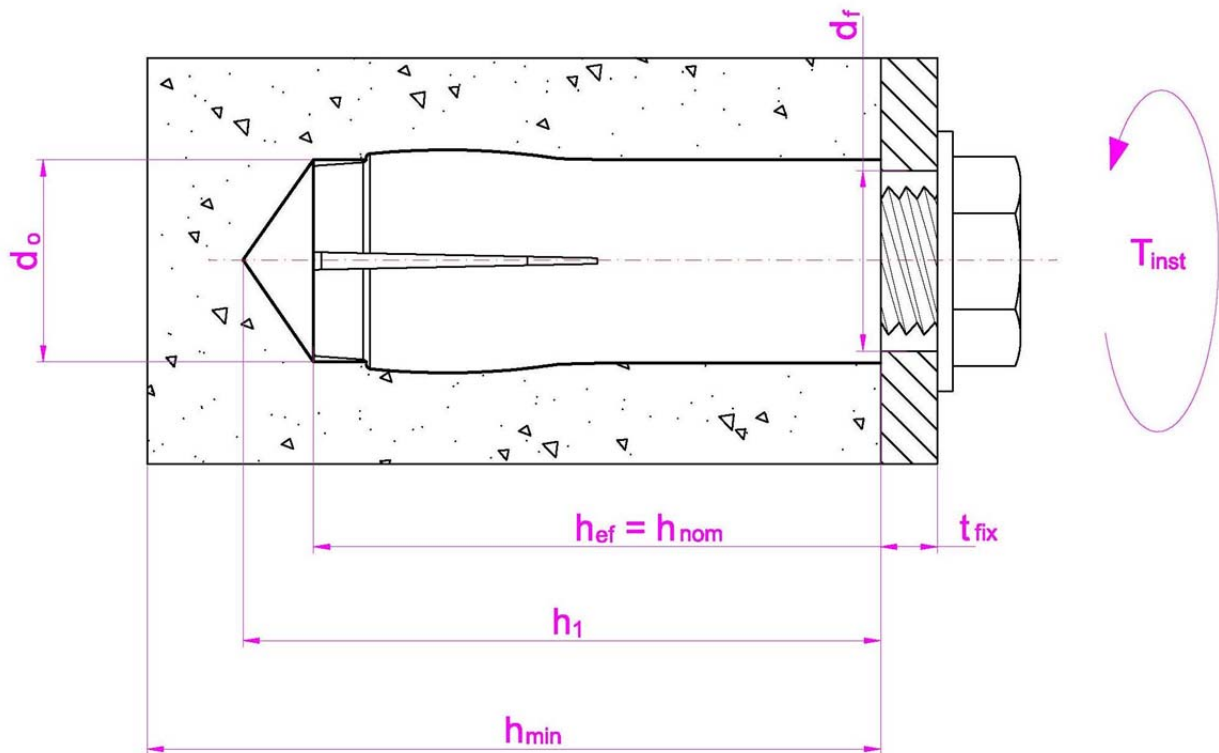

- h_{ef} : Effective anchorage depth
- h_1 : Depth of drilled hole
- h_{nom} : Overall anchor embedment depth in the concrete
- h_{min} : Minimum thickness of concrete member
- t_{fix} : Thickness of fixture
- d_0 : Nominal diameter of drill bit
- d_f : Fixture clearance hole diameter

The screw or threaded rod to use shall be property class 4.6 / 5.6 / 5.8 / 6.8 / 8.8 according to ISO 898-1.

The length of the screw shall be determined depending on thickness of fixture t_{fix} , admissible tolerances and available thread length $l_{s,max}$ as well as minimum screw depth $l_{s,min}$.